

G Speedway

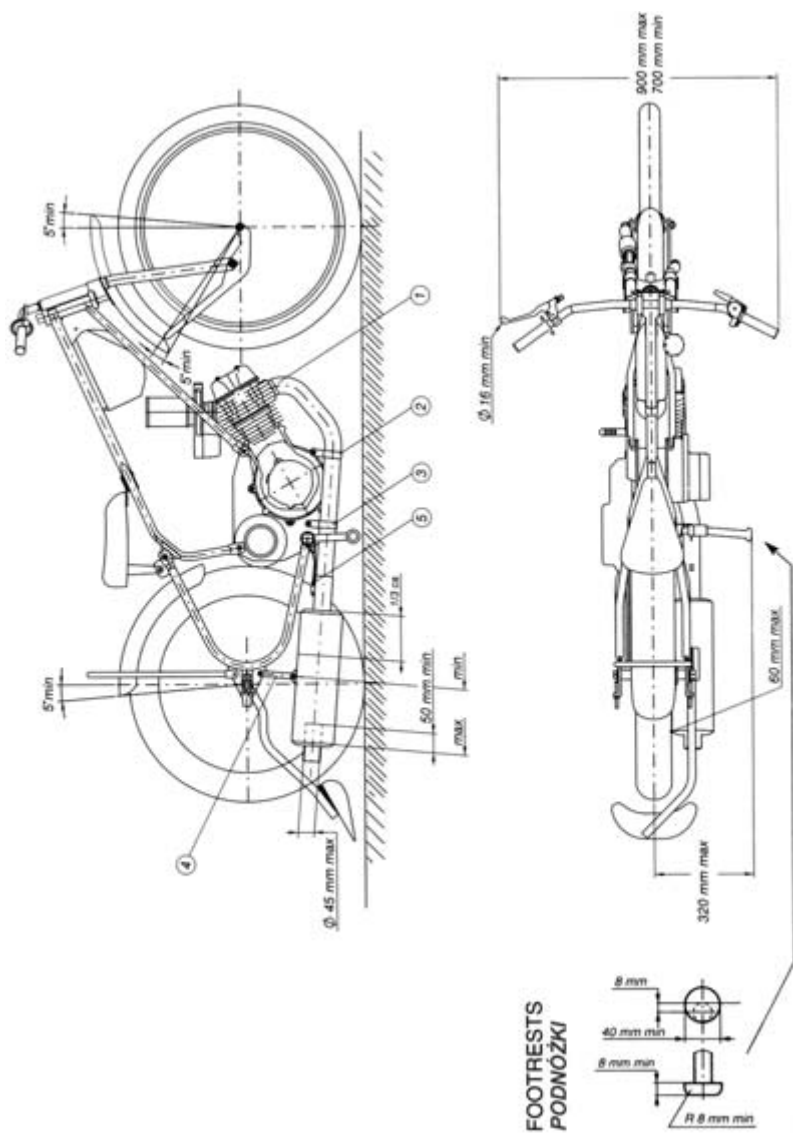

G Speedway

CHAIN GUARD
OSŁONA ŁAŃCUCHA

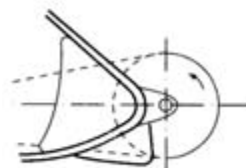

OPEN TRANSMISSION GUARDS
OSŁONA OTWARTYCH NAPĘDÓW

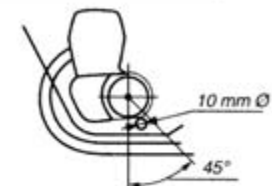

CARBURETTOR SECTION
PRZEKRÓJ GAŹNIKA

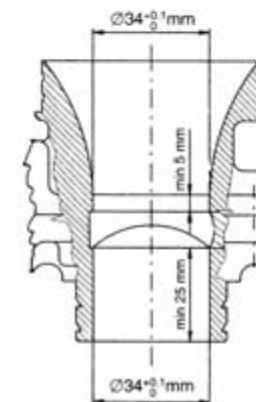
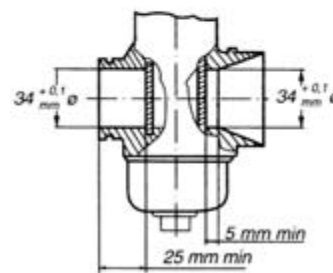

G bis

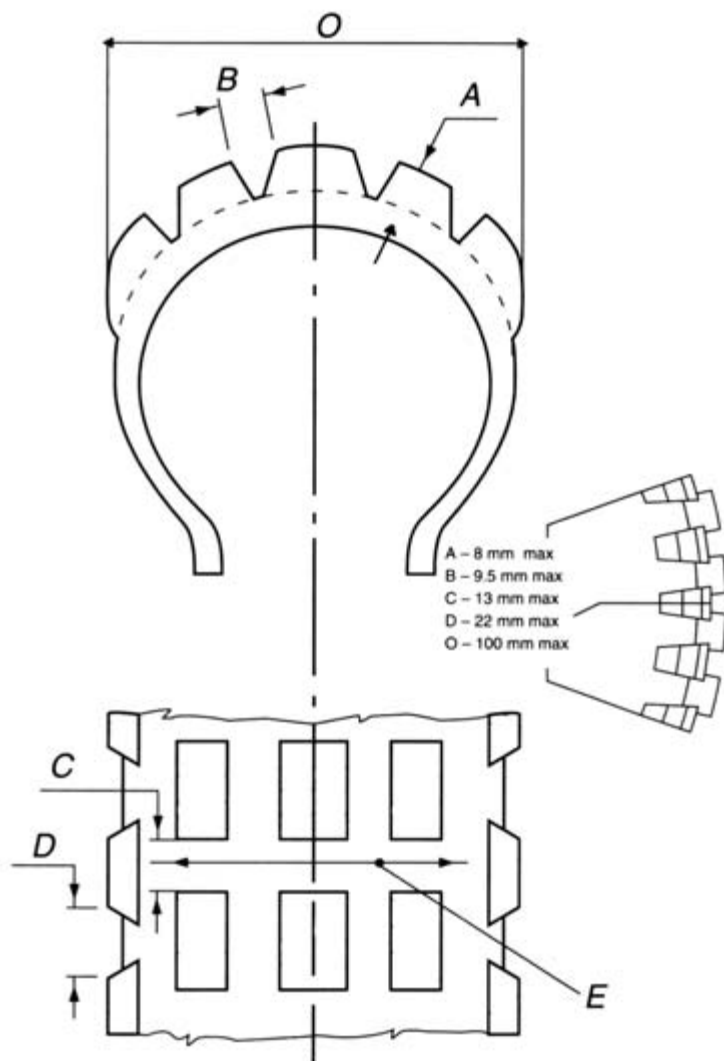

MOTOBALL / PIŁKA MOTOROWA

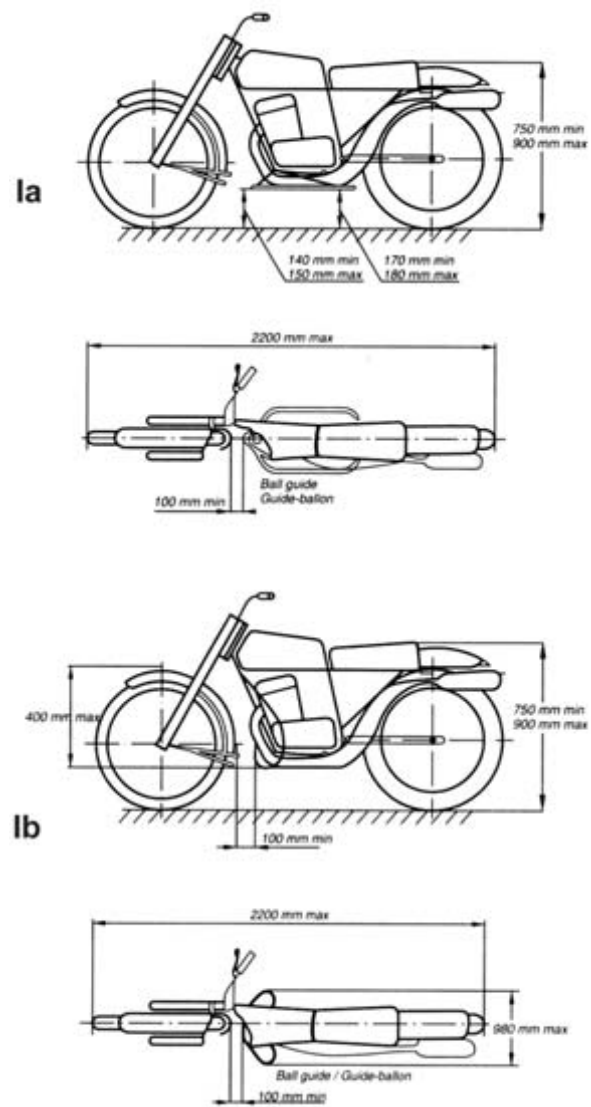

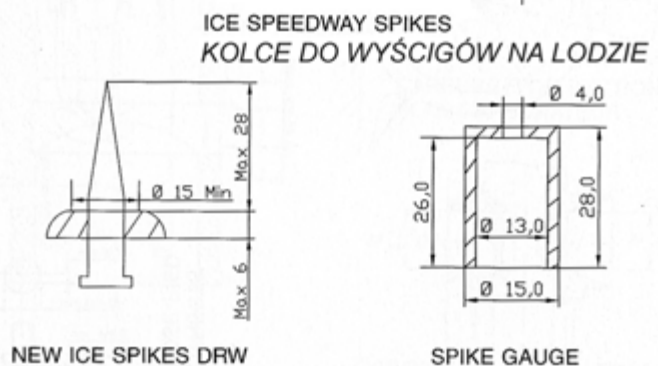
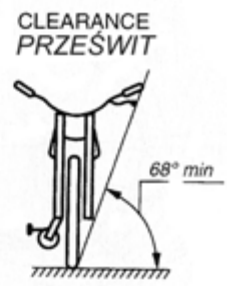
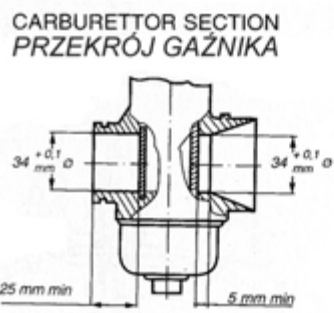
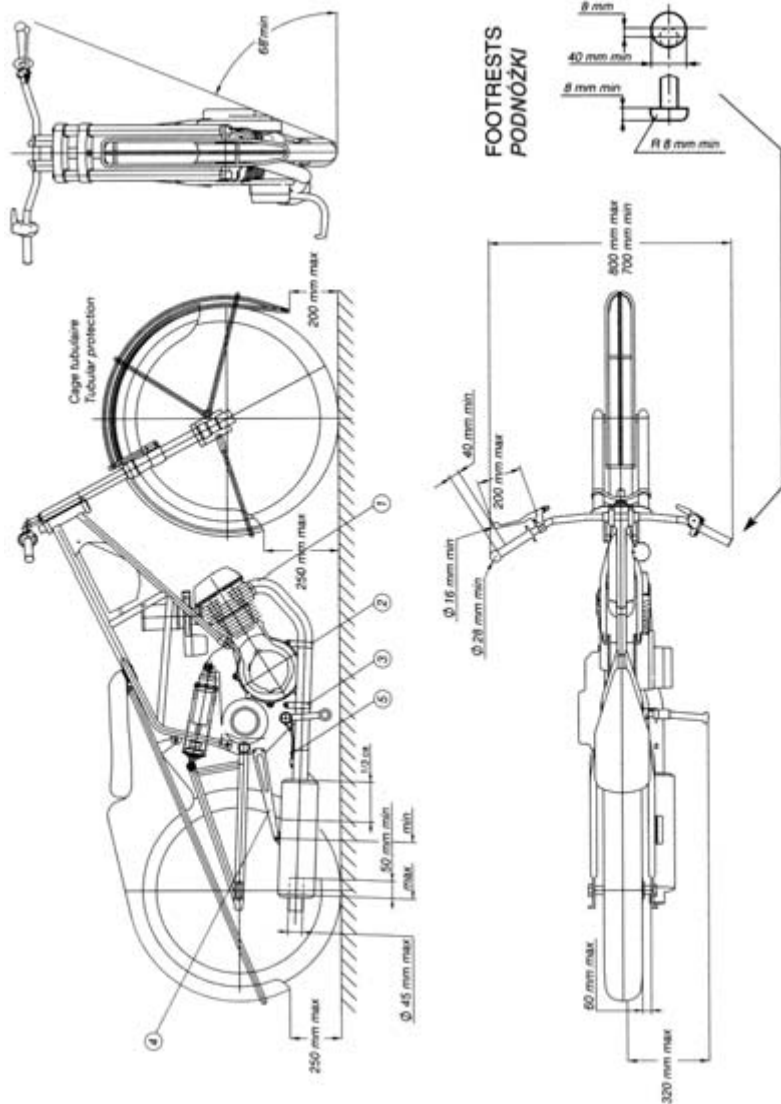

LONG TRACK / DŁUGI TOR

K

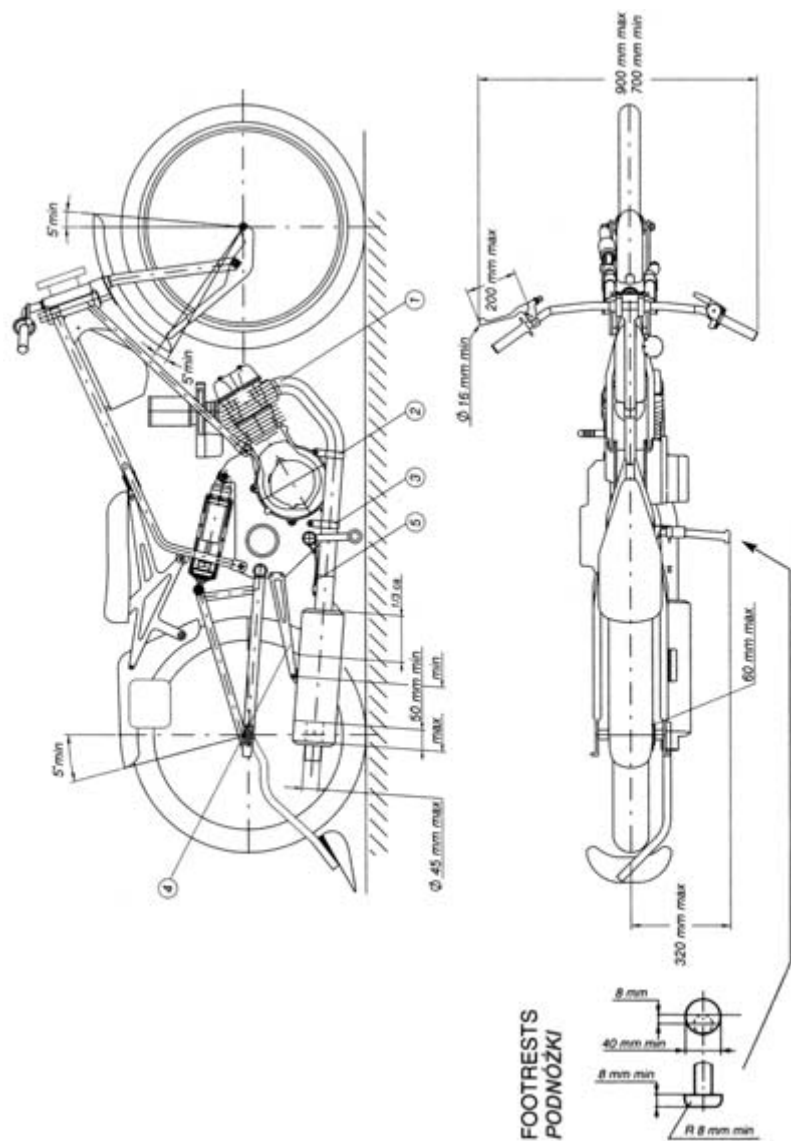

LONG TRACK / DŁUGI TOR

K

OPEN TRANSMISSION GUARDS
OSŁONA OTWARTYCH NAPĘDÓW

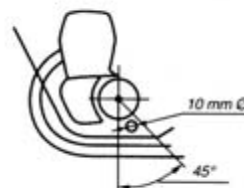

CHAIN GUARD
OSŁONA ŁAŃCUCHA

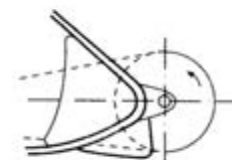

CARBURETTOR SECTION
PRZEKRÓJ GAŹNIKA

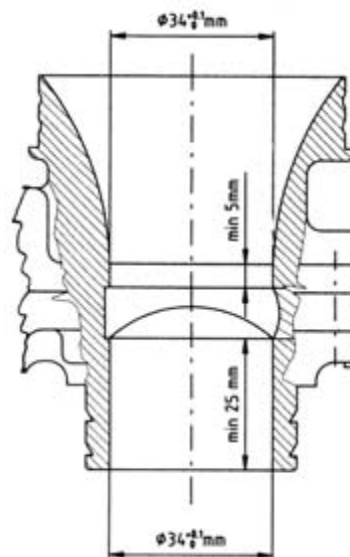

CARBURETTOR SECTION
PRZEKRÓJ GAŹNIKA

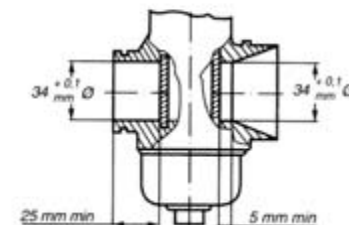

TRACK SIDECAR (see art. 01.53)
MOTOCYKL Z BOCZNYM WÓZKIEM
DO WYŚCIGÓW TOROWYCH
 (patrz art. 01.53)

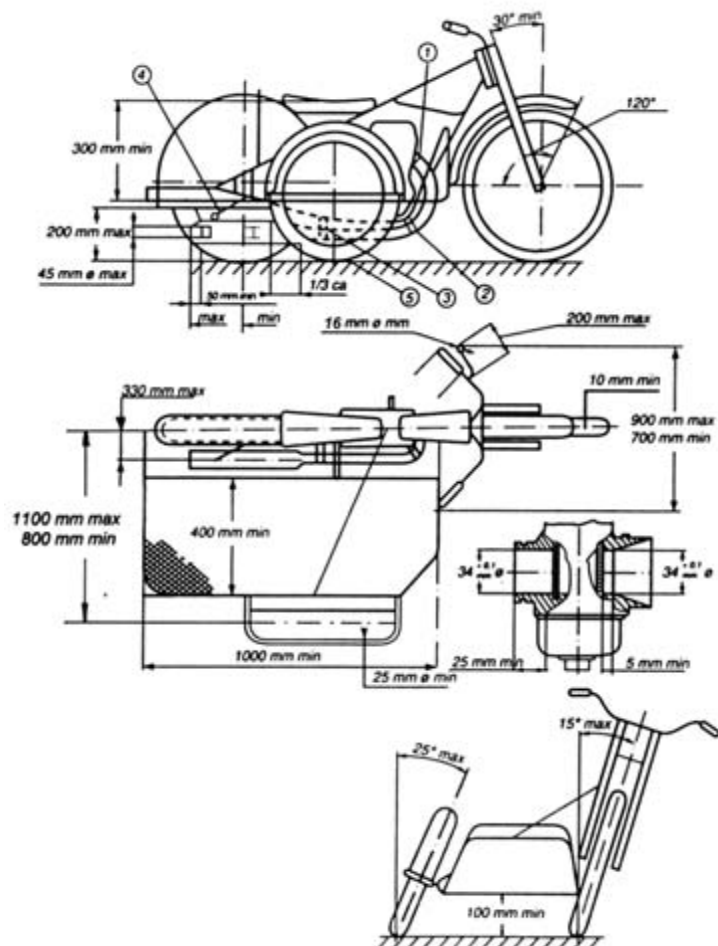

L

NUMBERS / NUMERY

O

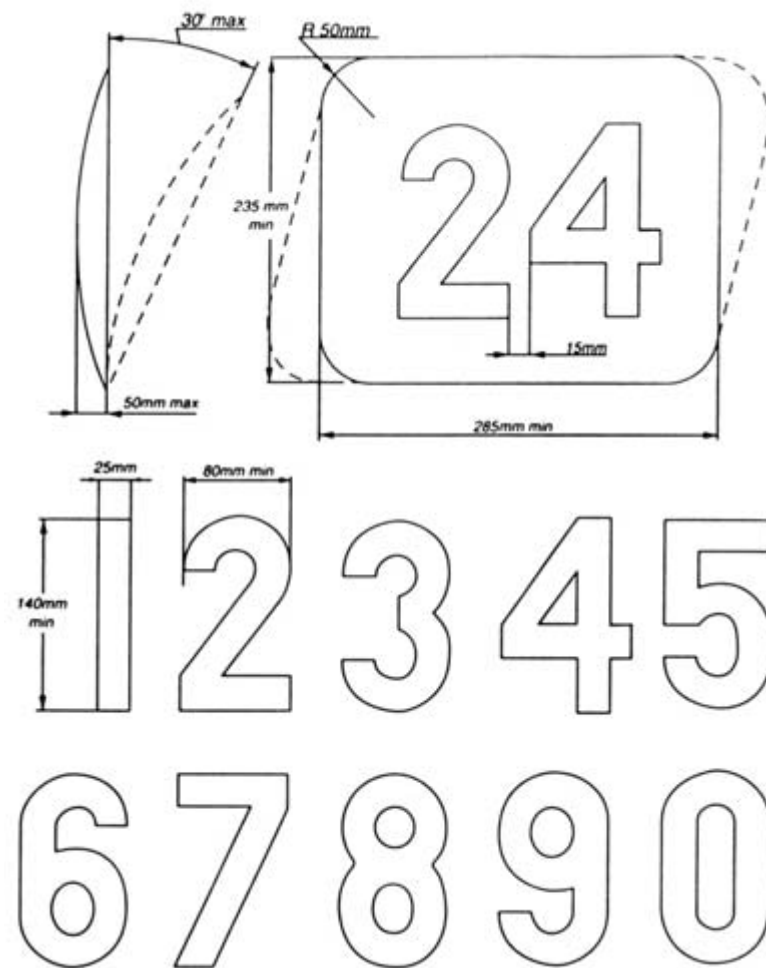

Futura Heavy

0123456789

Futura Heavy Italic

0123456789

Univers Bold

0123456789

Univers Bold Italic

0123456789

Oliver Med.

0123456789

Oliver Med. Italic

0123456789

Franklin Gothic

0123456789

Franklin Gothic Italic

0123456789

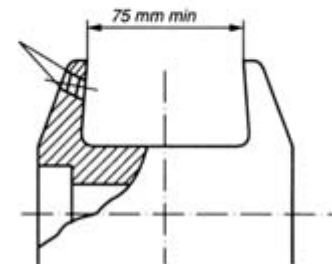
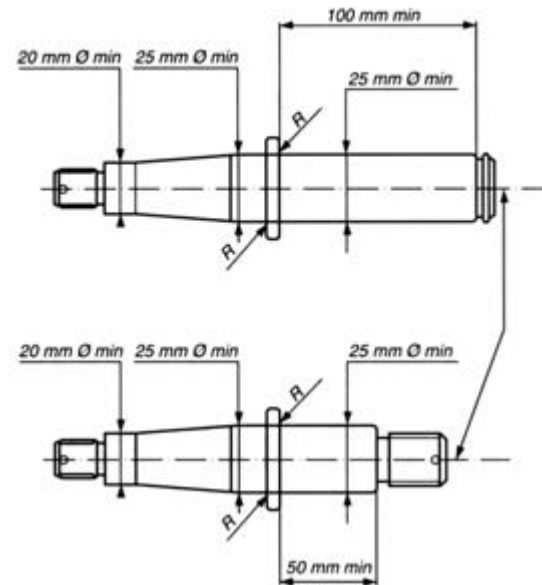

DIRT DEFLECTOR / DEFLEKTOR

S

ART. 01.31

P

TERE TO DEFLECTOR CLEARANCE / INSTALATION ANGLE
 PRZEŚWIT DEFLEKTORA / KĄT INSTALACJI

Dirt deflector / Deflektor
 Artykuł 58.03

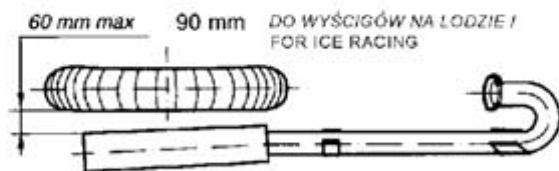
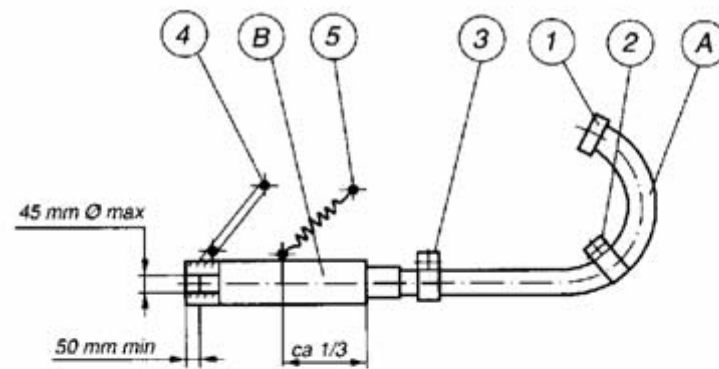
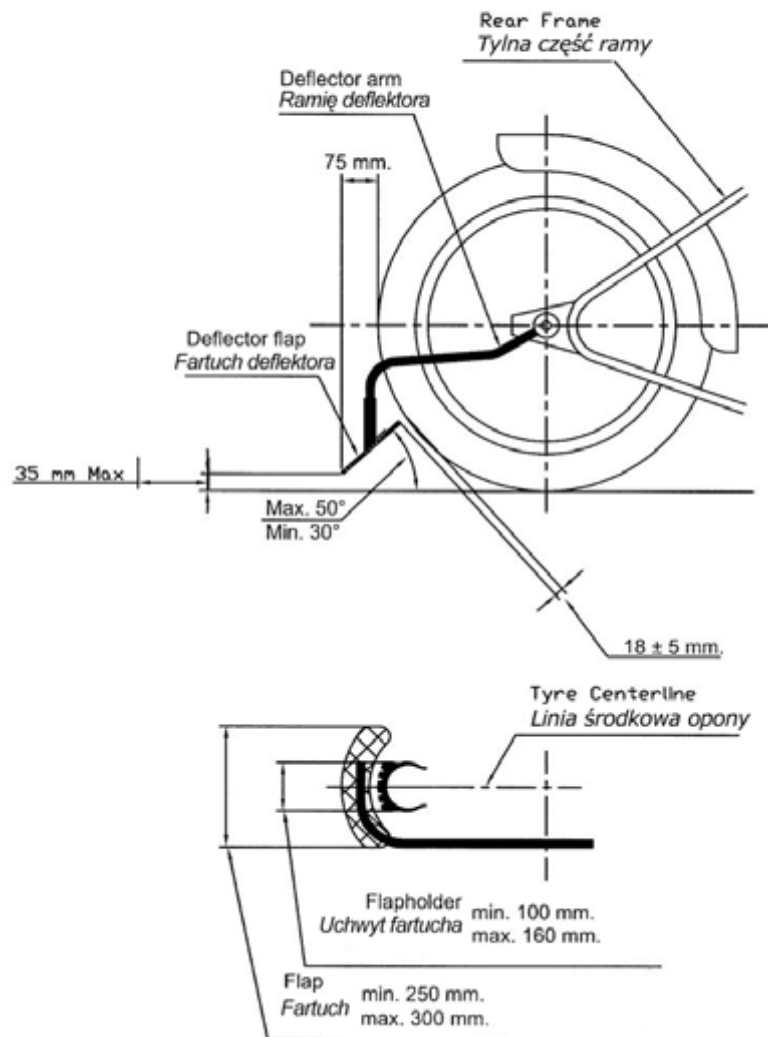

A = Rura wydechowa (Exhaust Pipe)
 B = Tłumik (Silencer)

TEN FITTING TESTS FOR HELMETS

10 TESTÓW DOPASOWANIA KASKU

1. Obtain correct size by measuring the crown of the head
Zrób dokładny pomiar szczytu głowy
2. Check there is no side to side movement
Sprawdź, czy nie ma przesuwu
3. Tighten strap securely
Zapnij dokładnie pasek
4. With head forward, attempt to pull up back of helmet to ensure helmet cannot be removed this way
Pochyl głowę do przodu, spróbuj ściągnąć kask do tyłu, upewniając się w ten sposób, czy kasku nie da się zdjąć w ten sposób



5. Check ability to see clearly over shoulder
Sprawdź, czy dobrze widzisz za sobą
6. Make sure nothing impedes your breathing in the helmet and never cover your nose or mouth
Upewnij się, czy przy założonym kasku nic nie przeszkadza w oddychaniu i nic nie zakrywa nosa i ust
7. Never wind scarf around neck so that air is stopped from entering the helmet. Never wear scarf under the retention strap
Nigdy nie zawiązuj chustki wokół szyi, gdyż blokuje to dostęp powietrza do kasku. Nigdy nie zakładaj chustki pod pasek.
8. Ensure that visor can be opened with one gloved hand
Upewnij się, czy można otworzyć maskę jedną ręką w rękawiczce
9. Satisfy yourself that the back of your helmet is designed to protect your neck
Sprawdź, czy tył kasku chroni szyję
10. Always buy the best you can afford
Zawsze kupuj najlepszy kask, na jaki Cię stać

INTERNATIONAL HELMETS STANDARDS

MIĘDZYNARODOWE STANDARDY KASKÓW

ECE 22 - 05 "P" (EUROPE)

The ECE mark consists of a circle surrounding the letter E followed by the distinguishing number of the country which has granted approval.

(EUROPA)

Znak ECE składa się z okręgu otaczającego literę E, po której następuje numer kraju zatwierdzającego.



E1 for Germany, **E2** for France, **E3** for Italy, **E4** for Netherlands, **E5** for Sweden, **E6** for Belgium, **E7** for Hungary, **E8** for Czech Republic, **E9** for Spain, **E10** for Yugoslavia, **E11** for UK, **E12** for Austria, **E13** for Luxembourg, **E14** for Switzerland, **E15** (- vacant), **E16** for Norway, **E17** for Finland, **E18** for Denmark, **E19** for Roumania, **E20** for Poland, **E21** for Portugal, **E22** for the Russian Federation, **E23** for Greece, **E24** for Ireland, **E25** for Croatia, **E26** for Slovenia, **E27** for Slovakia, **E28** for Bielo Russia, **E29** for Estonia, **E30** (- vacant), **E31** for Bosnia and Herzegovina, **E32** for Letonie, **E34** for Bulgaria, **E37** for Turkey, **E40** for Macedonia, **E43** for Japan, **E44** (- vacant), **E45** for Australia, **E46** for Ukraine, **E47** for South Africa, **E48** for New Zealand.

Below the letter **E**, the **approval** number should always begin with 05. Below the approval number is the serial production number. (Label on retention system or comfort interior).

Poniżej litery **E**, numer znaku zatwierdzającego musi zawsze zaczynać się od 05. Poniżej tego numeru jest numer seryjny produktu.



(JAPAN) (JAPONIA)

JIS T 8133 : 2000

(Label affixed inside the helmet).
(Etykieta przyklejona wewnątrz).



(USA) SNELL M2005

(Label affixed inside the helmet).
(Etykieta przyklejona wewnątrz).

For more details consult the F.I.M. Technical Rulebook
Więcej szczegółów jest Technicznym Regulaminie FIM

TABLE 1
TABLICA 1

	Max. increase of radius Augmentation max. du rayon (dyn) tyre / pneu		Stat. distance of surface fixed from m/cycle parts Distance entre surface et éléments fixes du m/cycle (tyre / pneu)		Min. depth of grooves Profil min. des rainures	Speed Vitesse	Rim / Width Largueur / Jante	Tyre Pneu	Rim / Jante Diamètre	**Tyre width Largueur pneu	WHEEL / ROUE	Max. engine cap. in cc Cylindrée max. en cc
	axial	radial	axial	radial								
	10	10	5	5	1.5	Over Au-dessus de 210 V	38	1.50	38	50	front/avant rear/arrière	50-80
	15	15	5	5	2.5	Over Au-dessus de 210 V	38	1.50	50	50	front/avant rear/arrière	125
	15	15	5	5	2.5	Over Au-dessus de 210 V	38	1.50	63	63	front/avant rear/arrière	250
	15	15	5	5	2.5	Over Au-dessus de 210 V	40.5	1.60	70	70	front/avant rear/arrière	350
	20	20	5	5	2.5	Over Au-dessus de 210 V	47	1.85	83	83	front/avant rear/arrière	500
	20	20	5	5	2.5	Over Au-dessus de 210 V	47	1.85	100	100	front/avant rear/arrière	750
	20	20	5	5	2.5	Over Au-dessus de 210 V	55	2.15	83	83	front/avant rear/arrière	1000
	10	10	5	5	2.5	Over Au-dessus de 210 V	55	2.15	110	110	front/avant rear/arrière	Sidecar (road) (route)
	10	10	5	5	2.5	Over Au-dessus de 210 V	--	--	220	254	front/avant rear/arrière	Speedway
	10	10	5	5	2.5	Over Au-dessus de 210 V	19"	19"	80	100	front/avant rear/arrière	Long track (longue)
	10	10	5	5	2.5	Over Au-dessus de 210 V	--	--	100	100	front/avant rear/arrière	Ice
	10	10	5	5	2.5	Over Au-dessus de 210 V	--	--	100	100	front/avant rear/arrière	Grass
	10	10	5	5	2.5	Over Au-dessus de 210 V	--	--	80	100	front/avant rear/arrière	Sidecar Track Racing
	10	10	5	5	2.5	Over Au-dessus de 210 V	--	--	16" min. 18" max. 22" max. 16" max.	100	Sidecar Wheel	

SOLO ROAD RACING
WYŚCIGI DROGOWE SOLO

** For road racing sidecars, tyre width dimensions refers to tread width. All others refer to overall width. / Dla motocykli z bocznym wózkiem do wyścigów drogowych, szerokość tylnej opony oznacza szerokość bieżnika. W pozostałych przypadkach oznacza całkowitą szerokość opony.

**LISTING OF HOMOLOGATED AND APPROVED PARTS
FOR TRACK RACING**
**LISTA HOMOLOGOWANYCH I ZATWIERDZONYCH
CZĘŚCI DO WYŚCIGÓW TOROWYCH**

Manufacturer Producent	Product identification Identyfikacja produktu	Applicable to: Odpowiedni do:	Valid from: Ważny od:
---------------------------	--	----------------------------------	--------------------------

(1) TYRES / OPONY (Art. 01.47)

MITAS 3.75-19/SW 16A CT.SW.97.18			04.04.'97
DUNLOP 3.75-19/366 CT.SW.97.17			04.04.'97
MITAS 3.75-19/SW-07 CT.SW.00.19(*)			05.04.'00
MITAS 3.75-19/SW-07 CTI.SW.00.19(*)			05.04.'00

(Barum=Mitas)

(2) SILENCERS / TŁUMINKI (Art. 01.37)

JAWA	FIM TRS.95.01	All machines	22.02.'95
		wszystkie motocykle	
JAWA	FIM TRS.95.02	All machines	22.02.'95
		wszystkie motocykle	
JAWA	FIM TRS.95.03	All machines	22.02.'95
		wszystkie motocykle	
KING	FIM TRS.95.04	All machines	09.05.'95
		wszystkie motocykle	

**(3) SPEEDWAY - DIRT DEFLECTORS / ŻUŻEL – DEFLEKTORY
(Art. 58.03)**

BARRY BRIGGS	BBDD/96/A/All	All machines	01.01.'98
		wszystkie motocykle	
BARRY BRIGGS	FIMDDBBR/9712/ SCB01	All machines	01.01.'98
		wszystkie motocykle	
DAVE STANDING	DASDD/97/A/All	All machines	01.01.'98
		wszystkie motocykle	
JAWA	DD-JAWA/2000/03	All machines	01.01.'00
		wszystkie motocykle	

**(4) LONGTRACK - GRASSTRACK DIRT DEFLECTORS
DEFLEKTORY TORY DŁUGIE I TRAWIASTE (Art. 58.03)**

JAWA	FIM DD/2002/04/LT	All machines	01.01.'02
		wszystkie motocykle	

Last update, ostatnia aktualizacja, 31/01/2005
Mies, CH